

New Air Chamber Bracket for Valx 420 x 180 drum brake axles

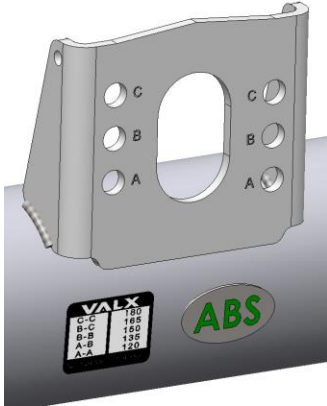

Improvement:

Valx designed a new air chamber bracket (ACB) for 420 x 180 drum brake axles to increase the clearance between the push rod of the brake cylinder and the axle beam, when mounted in the lowest A-A position (slack adjuster lever length of 120 mm).

What is the difference:

The new ACB is a little higher than the old one. The result is that the brake chamber will be closer to the chassis, floor or other parts of the trailer. The maximum height difference between the old ACB and the new ACB is worst case 28 mm (air suspension loaded on bump without air) with a 24/30" spring break chamber mounted on the ACB.

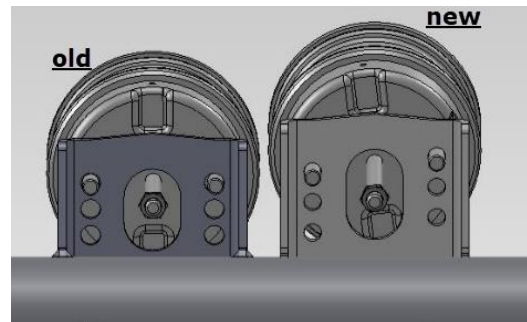

From when is this new ACB available:

This new ACB is used on axles with the grooves on the bottom (MBS air suspension) and on axles without a groove having a production date of April 2017 onwards. All axles with the grooves on the top (MBS-V2 air suspension) have been delivered with the new ACB since its introduction.

Special ACB's:

Valx also does have some special ACB's like the hanging ACB (on bottom of the axle) and the front ACB (brake cylinder on the front of the axle)

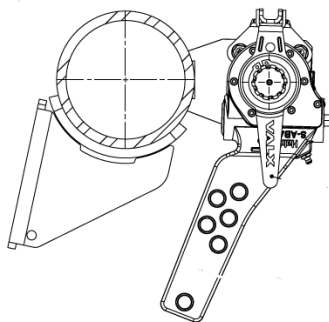

Hanging ACB

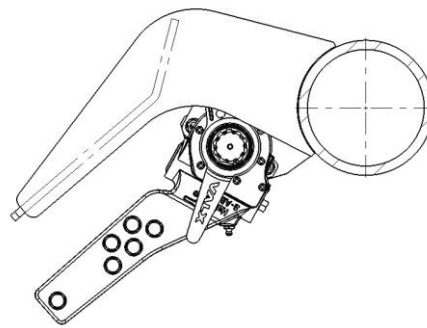

Front ACB

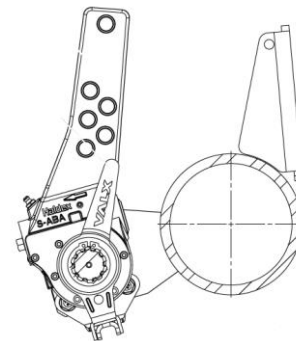

Standard ACB

Date:	23-03-2018
Name:	G. Colen
Version:	VF-TA-0007-A